



MMG Műszerszerviz Kft.

1036 Budapest, Dereglye u. 1.,

Tel/fax: 204-2252, Tel:203-7443

Web: www.mmg.hu, E-mail: info@mmg.hu

FOR DESIGNS WITH CONVERTER A MANUAL IS ENCLOSED TO THE RELEVANT CONVERTER

APPLICATION

- For remote measurement of temperature of gases, for which the properties of the material of the protective tube are suitable; up to the overpressure 100 kPa (e.g. in furnaces)
- Design with converter
 - o To convert signal of the thermoelectric sensor to unified output signal 4 to 20 mA or digital signal (converter with HART protocol)
 - o In explosive environment pursuant to the type of the converter EExi (refer to enclosed converter manual)

The sensors with converter are rated products pursuant to the Act No. 22/1997 Coll. and Compliance Certificate **EC-11331P** is issued for them.

DESCRIPTION

The sensor consists of a replaceable measuring insert with flange and terminal board or installed two-wire converter (insulated or non-insulated, even in design EExi) and protective armature. The protective armature consists of the metal protective tube of the sensor and the head.

The head is provided with a sealing outlet for the connection wiring.

A connecting flange or a weld-on piece with a threaded ring is used to install the sensor in the technological equipment.

The sensor with converter is supplied from an external source. The installed converter is set-up to the required range at the sensor manufacturer.

To measure temperature, a defined change of thermoelectric voltage of the thermocouple in dependence on the change of temperature of the measured environment is used.

TECHNICAL DATA

The sensor is designed pursuant to ČSN EN 61140 ed.2 as an electrical equipment of protection class III for the application in networks with the category of overvoltage in the installation II and pollution grade 2 pursuant to ČSN EN 61010-1, the follow-up (evaluation) device shall comply with Article 6.3 of the said standard.

Measuring range:

- for thermocouple of type "J" 0 to 800 °C
- for thermocouple of type "K" 0 to 1100 °C

This range is only recommended; it depends on the composition of the atmosphere, in which the sensor is located.

- In oxidation atmosphere, max. temperature may be up to 1100 °C
- In sulphur and carburizing atmosphere, max. temperature shall be below 1000 °C

Electrical strength pursuant to ČSN EN 61010-1, Article 6.8.4: 500 V eff

(only measuring insert without converter or design with insulated converter)

Electrical insulation resistance pursuant to ČSN EN 61515:

min. 1000 MΩ, at ambient temperature 20 ± 15 °C and max. 80 % relative humidity

Power supply of converter:

DC 24V, from source SELV, e.g. INAP 16, INAP 30, INAP 31 or INAP 901

Other data of converter: refer to the enclosed manual

Coverage pursuant to ČSN EN 60529:
IP 65

Operation position:

discretionary, the outlet shall not be situated upwards

Type of operation: continuous

Sensor weight:

L 500	0.745 kg
L 800	1.045 kg
L 1000	1.275 kg
L 1600	1.875 kg
L 2000	2.345 kg

Applied materials:

- jacket of thermocouple INCONEL 600
- protective tube in the whole length from heat-resisting steel 1.4845
- head chromated aluminium alloy painted with aluminium paint
- head clamps of the terminal board brass with Ni surface

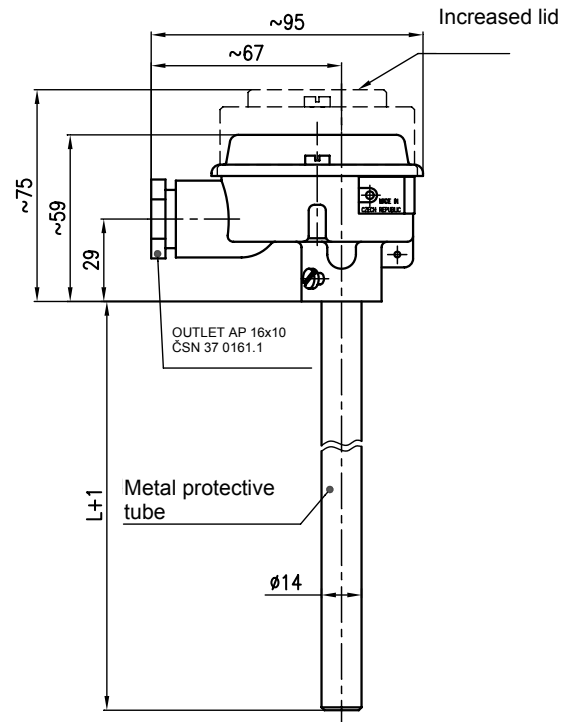

VIEW INTO SENSOR HEAD:

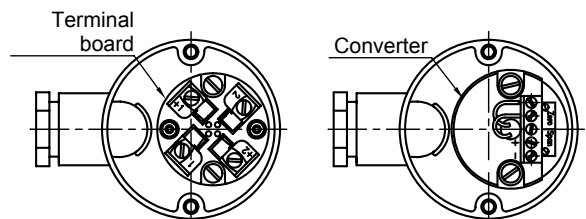

CONNECTION SCHEME

with converter

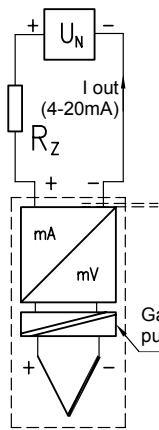

without converter:

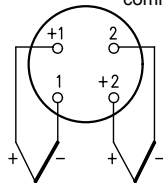

with converter
with HART protocol

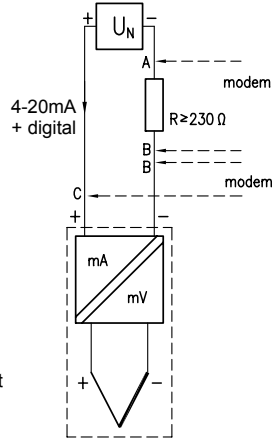

A-B and B-C options of connection of the control unit (HART modem, HART communicator)

DESIGNATION

Data on head label

- Trade mark of the manufacturer
- Made in Czech Republic
- Sensor type / tolerance class
- Measuring range or set-up converter range
- Product ordering number
- Coverage
- Production time code
- Output signal 4 to 20 mA (design with converter)
- Mark of non-explosiveness and No. of the EC Certificate of type test (design with converter EExi)

Data on aluminium label of measuring insert:

- Trade mark of the manufacturer
- Type of thermoelectric sensor
- Tolerance class
- Time code

Data on head of sensor with converter

- Mark CE or mark CE with identification number of the notified person (for converter EExi)

DELIVERY

Unless agreed otherwise with the customer, each delivery includes

- Delivery note
- Sensor pursuant to purchase order
- Accessories to be ordered separately :
connecting flange or weld-on piece with a threaded ring
- Optional accessories to the sensor with programmable converter
 - o Configuration (parameterization) programme pursuant to the required converter
 - o Communication modem (for serial port RS 232C) pursuant to the required converter
- Accompanying technical documentation in Czech
 - o Product quality and completeness certificate, which also serves as the warranty certificate
 - o EC Compliance Certificate (for converter EExi)
 - o Calibration sheet (for calibrated design)
 - o Product manual

If it is established in the purchase contract or agreed otherwise, the following documentation can be also delivered with the product

- Copy of the Inspection Certificate 3.1 for the material of the protective tube with the casting number
- EC Compliance Certificate for design with converter
- Copy of EC Certificate of type test pursuant to the Decree of the Government 23/2003 Coll. for design with converter EExi

CERTIFICATION

113 31/P

- Non-explosiveness EExi, EC Certificate of type test pursuant to the Decree of the Government 23/2003 Coll. (according to the converter type)

OPERATION CONDITIONS

The environment is defined by the group of parameters and their severity grades IE 36 pursuant to ČSN EN 60721-3-3 and the following operation conditions.

Ambient temperature for sensor head:

- max. 150 °C for design without converter
- for design with converter pursuant to the type of converter
- (refer to the enclosed manual)

Relative ambient humidity:

- 10 to 100 % with condensation, with upper level of water content 29 g H₂O/kg of dry air

Atmospheric pressure: 70 to 106 kPa

Maximum speed of flow of gaseous medium: 2 m/s

Vibrations:

Nominal length L [mm]	500 to 1000	1600 to 2000
Frequency range [Hz]	10 to 55	
Drift amplitude s _a [mm]	0.15	0.075
Acceleration amplitude a _a [m.s ⁻²]	19.6	9.8

METROLOGICAL DATA

Sensor: measuring thermocouple **J** (Fe-CuNi) or **K** (NiCr-NiAl) pursuant to ČSN EN 60584-1, tolerance class 2 pursuant to ČSN IEC 584-2
double with insulated measuring connection for design without converter
single with insulated measuring connection for design with converter

Output signal

of analogue converter (linear with thermoelectric voltage):
4 to 20 mA

of programmable converter (linear with measured temperature):
4 to 20 mA (+ digital for HART protocol)

Temperature response time pursuant to ČSN IEC 751 in whirling water (characteristic value):

τ _{0,5}	55
τ _{0,9}	190

PACKING

Both the sensors and accessories are delivered in a packing ensuring resistance to the impact of thermal effects and mechanical effects pursuant to controlled packing regulations.

TRANSPORT

The converters may be transported on conditions corresponding to the set of combinations of classes IE 21 pursuant to ČSN EN 60721-3-2 (i.e. by airplanes and trucks, in premises that are ventilated and protected against atmospheric conditions).

STORAGE

The sensors may be stored on conditions corresponding to the set of combinations of classes IE 11/1K3 pursuant to ČSN EN 60721-3-1 (i.e. in places with temperature from -5 to 45 °C and humidity from 5 to 95%, without a special threat of an attack with biological agents, with vibrations of small significance and not situated close to sources of dust and sand).

CALIBRATION

It is realized pursuant to TPM 3322-94 and in compliance with ČSN EN 584, usually in three temperature points evenly distributed within the operation range of the sensor or in the points according to the requirement of the customer. Calibration sheets with measured data are issued for calibrated sensors.

ORDERING OF TEMPERATURE SENSORS

The purchase order shall include

- Name
- Product ordering number
- Measuring range (only for design with converter)
- If calibration is required and in what temperature points
- If a connecting flange or weld-on piece with a threaded ring is required
- If optional accessories to the sensor with programmable converter are required
- Other (special) requests
- Number of pieces

PURCHASE ORDER EXAMPLE**Standard design:**

Rod thermoelectric temperature sensor
with metal protective tube, with converter
113 319 842 / HCF
0 - 600 °C

6 pcs

Upon a special request:

Rod thermoelectric temperature sensor
with metal protective tube, without converter
113 315 849
Nominal length L = 1800 mm
6 pcs

ORDERING ACCESSORIES

The purchase order shall include:

- Name
- Product ordering number
- Number of pieces

PURCHASE ORDER EXAMPLE**Standard design:**

Connecting flange
991 UP 14 - 5 pcs

DESIGN AND ORDERING OF TEMPERATURE SENSOR, TYPE 113 31:

SPECIFICATIONS		ORDERING NUMBER				
		113 31	5	x	x	x
Jacketed thermoelectric couple Ø 4.5 mm (insulated measuring end)	J (Fe-CuNi) pursuant to ČSN EN 60584-1			8		
	K (NiCr-NiAl) pursuant to ČSN EN 60584-1			K		
Material of protective tube heat-resisting steel (in the whole length L)	1.4845 (17 255)				4	
Nominal length L [mm]	350					1
	500					2
	800					3
	1000					4
	1600					5
	2000					6
	3000					7
	Other (max. 3000 mm) *)					9

*) Only as a special requirement after an agreement with the manufacturer

DESIGN OF TEMPERATURE SENSORS WITH CONVERTER, TYPE 113 31/P

SPECIFICATIONS				ORDERING NUMBER					
				113 31	9	x	x	x	/xxx
Jacketed thermoelectric couple Ø 4.5 mm (insulated measuring end)	J (Fe-CuNi) pursuant to ČSN EN 60584-1			8					
	K (NiCr-NiAl) pursuant to ČSN EN 60584-1			K					
Material of protective tube heat-resisting steel (in the whole length L)	1.4845 (17 255)				4				
Nominal length L [mm]	350						1		
	500						2		
	800						3		
	1000						4		
	1600						5		
	2000						6		
	3000 *)						7		
	Other (max. 3000 mm) *)						9		
Converter type		Galvanic separation	Increased lid	EExia	Range [°C]				
Analogue output signal, linear with thermoelectric voltage	APAQ-HCF				Adjustable range			/HCF	
	APAQ-HCFX *)			•				/HCFX	
Programmable output signal, linear with temperature	TK	•	•		Programmable range			/TK	
	TK-ex *)	•	•	•				/TKX	
	IPAQ-H	•	•					/IPAQH	
	IPAQ-HX *)	•	•	•				/IPAQHx	
HART protocol linear output signal with temperature	MINIPAQ-H		•				/MINIPAQ		
	TK-H	•	•				/TKH		
	TK-H-ex *)	•	•	•			/TKHX		
	MESO-H	•	•				/MESOH		
	MESO-HX *)	•	•	•			/MESOHx		
	Other *)		•				/99		

*) Only as a special requirement after an agreement with the manufacturer

Note: As a default, the sensors are delivered with converter APAQ-HCF. Specify the required measuring range in the purchase order in wording. Minimum range of measured temperature shall be entered pursuant to the parameters of the converter. Temperature range is given by the type of the thermocouple.

ACCESSORIES - to be ordered separately

SPECIFICATIONS		ORDERING NUMBER
Connecting flange		991 UP 14
Weld-on piece with a threaded ring	Material: carbon steel	991 NVP6 D14 13
	Material: corrosion resistant steel	991 NVP6 D14 72

INSTALLATION AND CONNECTION

The sensor installation shall be realized by means of the installation flange or a weld-on piece with a threaded ring.

FLANGE INSTALLATION

Weld the bottom part of the flange onto the wall of the technological equipment. In the connecting flange, the sensor can be moved back and forth after releasing two screws M6x14, whereby the required sensor immersion can be adjusted.

INSTALLATION OF WELD-ON PIECE WITH THREADED RING shall be realized pursuant to the instruction label as follows:

- 1) Uninstall the complete weld-on piece by unscrewing the cap-nut
- 2) Weld the weld-on piece itself (after possible shortening) onto the wall of the piping or other technological equipment
- 3) On the metal protective tube of the rod temperature sensor, put the cap-nut, the thrust ring and the threaded ring in the said order,
- 4) Slide the temperature sensor with put-on components pursuant to point 3 into the prepared weld-on piece and only tighten it after the definitive selection of the immersion (recommended torque is 60 to 70 Nm).



WARNING

The length of the immersion part cannot be changed repeatedly; the sensor can only be uninstalled!

With respect to maintaining metrological properties and the longest possible service life, it is not recommended to install the sensors in places with high turbulence of the medium, which is caused e.g. by a rapid transition from a small diameter of the piping to a larger one (when failing to comply with the required shape and dimensions of diffuser behind the flow meter). Recommended distance of the temperature sensor from the installation flange of the flow meter is min. 1 m.

ELECTRICAL CONNECTION

The electrical connection may be only realized by qualified workers pursuant to § 5 of the Decree 50/1978 Coll. The terminal board of the sensor (converter) is accessible after the removal of the lid of the head that is connected with two screws.

Connect the evaluation devices to the sensor with a cable with a double insulation with outer diameter from 5 to 12 mm, internal wires with Cu core (sensor with converter) or compensation wiring (sensor without converter) with the cross section 0.5 to 2.5 mm². Seal the cable outlet of the sensor properly. In the environment with interfering signals, use shielded cables in the supply circuit. If it is not possible to exclude influencing the measurement, ground the wiring. Shielding may only be grounded in one point.

The cable should not be placed together with power cables. It is recommended to support the cable along its length between the sensor and the follow-up device.



WARNING

(it applies to sensor with converter EExi) **EExi parameters shall be complied with pursuant to the enclosed converter manual.**



To ensure safety, a spark-safe source shall be always used pursuant to the converter manual, e.g. INAP 901 ordering number 901 000 101.

Surface temperature of the converter may not exceed maximum surface temperature for that particular temperature class.

If the converter is installed in a dangerous zone, the sensor shall be grounded electrostatically.

Programmable converter may not be connected to a computer or a HART communicator, if the converter is located in explosive environment.

COMMISSIONING

After the sensor installation and connection of the follow-up (evaluation) device to the supply voltage (and the settlement period of the converter), the equipment is prepared for operation.

OPERATION AND MAINTENANCE

The sensor does not require any operation and maintenance.

CONNECTING FLANGE (example of installation)

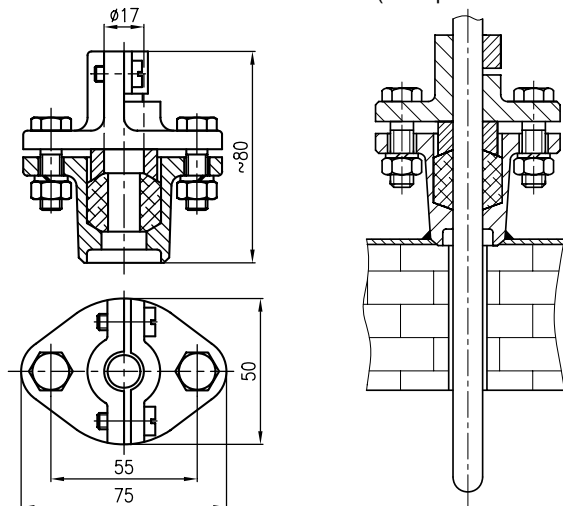
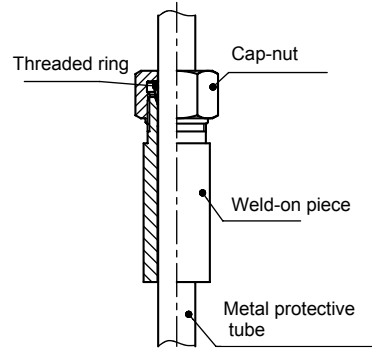

FIGURE 1 - EXAMPLE OF OPERATION CONNECTION

WELD-ON PIECE WITH A THREADED RING



SPARE PARTS

Spare parts shall be delivered by the manufacturer. Relevant measuring inserts, protective tubes or head can be ordered pursuant to the offered price list of spare parts.

WARRANTY

Pursuant to § 429 of the Commercial Code and the provisions of § 620 (2) of the Civil Code, the manufacturer warrants for technical and operation parameters of the product specified in the manual. The warranty period is 24 months from the receiving of the product by the customer, unless established otherwise in the contract. The rejection of defects shall be enforced in writing at the manufacturer within the warranty period. The rejecting side shall identify the product name, ordering and manufacturing numbers, date of issue and number of the delivery note, clear description of the occurring defect and the subject of the claim. If the rejecting side is invited to send the device for repair, it shall do so in the original package of the manufacturer and/or in another package ensuring safe transport.

The warranty shall not apply to defects caused by unauthorized intervention into the device, its forced mechanical damage or failure to comply with operation conditions of the product and the product manual.

REPAIRS

The sensors shall be repaired by the manufacturer. They shall be sent for repair in the original or equal package without accessories.

DISABLING AND LIQUIDATION

They shall be realized in compliance with the Waste Act No. 106/2005 Coll.

Both the product and its package do not include any parts that could impact the environment.

Products that are withdrawn from operation, including their packages (with the exception of products marked as electrical equipment for the purposes of return withdrawal and selected salvage of electrical waste), may be disposed of to the sorted or unsorted waste pursuant to the type of waste.

The manufacturer realizes free return withdrawal of marked electrical equipment (from 13.8.2005) from the consumer and points out the danger connected with their illegal disposal. The package of the sensor can be recycled completely. Metal parts of the product are recycled, non-recyclable plastic materials and electrical waste shall be disposed of in compliance with the aforesaid Act.

of temperature sensor with converter in loop 4 - 20 mA

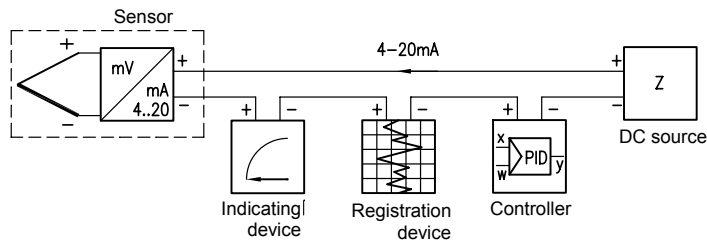

MMG Műszerszerviz Kft.
1036 Budapest, Dereglye u. 1.,
Tel/fax: 204-2252, Tel:203-7443
Web: www.mmg.hu, E-mail: info@mmg.hu